

Operator's manual



TruTool N 200 (3A5)
TruTool PN 200 (3A5)
TruTool PN 201 (3A5)

Nibbler

Table of contents

1	Safety	2
1.1	General safety information	2
1.2	Specific safety information for nibblers	2
1.3	Additional safety warnings	2
2	Description	4
2.1	Intended use	4
2.2	Technical data	5
2.3	Noise and vibration information	7
2.4	Icons	8
3	Setting work	10
3.1	Select tool (TruTool N 200 / TruTool PN 200 / TruTool PN 201)	10
3.2	Setting the speed	11
3.3	Chip bag (optional)	11
4	Operation	13
4.1	Working with the TruTool N 200 / TruTool PN 200 / TruTool PN 201	13
4.2	Changing the cutting direction	13
4.3	Nibbling with templates (TruTool N 200)	14
4.4	Producing interior cutouts	15
5	Maintenance	16
5.1	Replacing the tool	16
5.2	Changing the die, punch guide and wearing plate (TruTool PN 200 / TruTool PN 201)	19
5.3	Checking loading status	20
5.4	Changing rechargeable battery	20
6	Accessories and consumables	21
6.1	Ordering consumables	22
7	Appendix: Declaration of conformity, guar- antee, replacement parts lists	24

1. Safety

1.1 General safety information

WARNING

Read all the safety information and instructions.

- Failure to comply with the safety information and instructions can cause electric shock, burns and/or serious injury.
- Retain all the safety information and instructions for future use.

1.2 Specific safety information for nibblers

WARNING

Risk of injury to hands.

- Do not reach into the processing line with your hands. When switching off the motor, the drive will run down.
- Hold the machine with both hands.

WARNING

Risk of injury from hot and sharp chips!

Chips exit the chip ejector at high speed.

- Use a chip bag.

WARNING

Risk of injury due to improper handling!

- Make sure the machine is always in a stable position when operating it.
- Never touch the tool while the machine is running.
- Always operate the machine away from your body.
- Do not operate the machine above your head.

1.3 Additional safety warnings

Personal safety Note

Do not let familiarity gained from frequent use of tools allow you to become complacent and ignore tool safety principles.

A careless action can cause severe injury within a fraction of a second.



Power tool use and care Note

Keep handles and grasping surfaces dry, clean and free from oil and grease.

Slippery handles and grasping surfaces do not allow for safe handling and control of the tool in unexpected situations.

2. Description

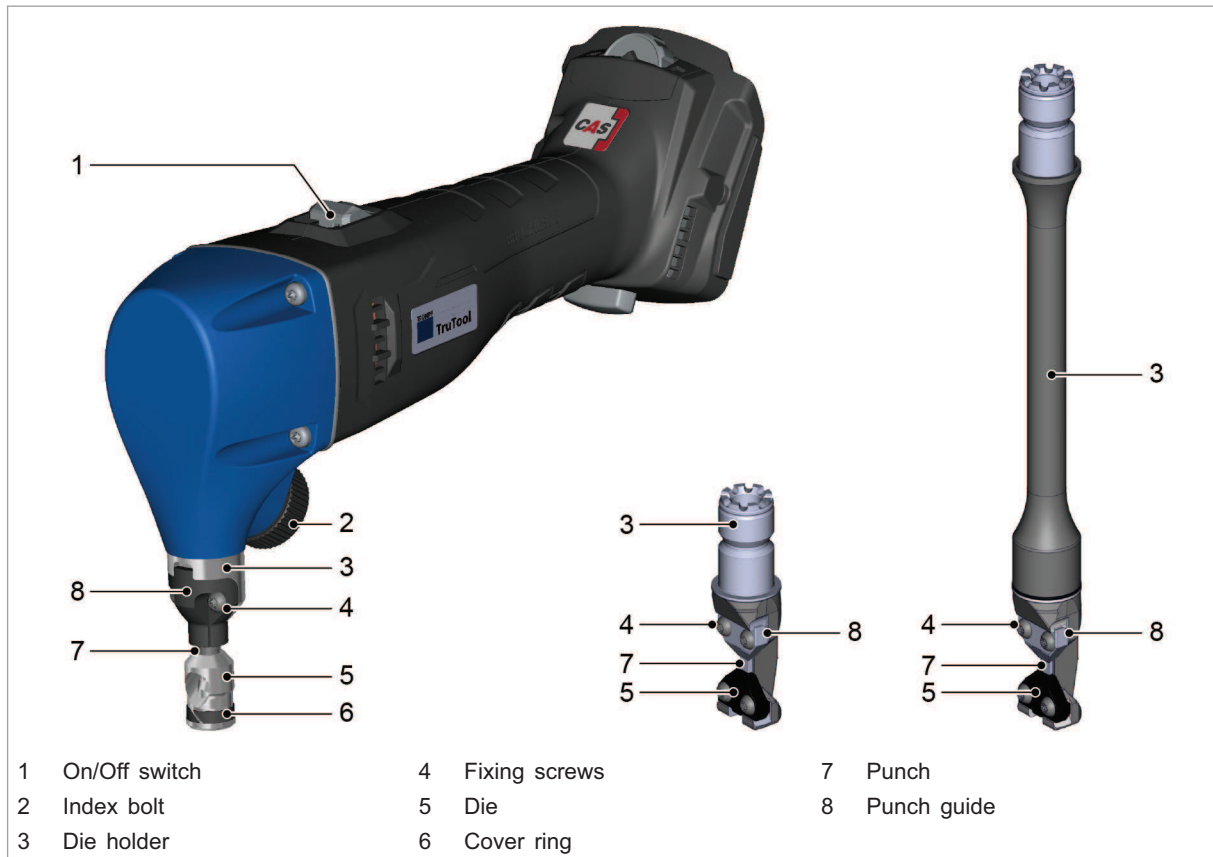

Fig. 111293

2.1 Intended use



Damage to the machine due to improper handling.

- Only use the machine for work and materials as described under "Intended use."

The TRUMPF nibbler TruTool N 200 is a hand-held battery-powered tool for the following applications:

- Slitting plate-shaped workpieces made of a punchable material such as steel, aluminum, non-ferrous heavy metals and plastic.
- Slitting pipes and machining corrugated sheets.
- Nibbling straight or curved exterior and interior cutouts.
- Nibbling along scribed lines or templates.

Notes

- Because of the hollow round punch, the nibbler can be rotated at any position such that processing can continue in any direction.
- The nibbling process produces cutting edges free of deformations.

The TRUMPF profiling nibbler TruTool PN 200 or TruTool PN 201 is a hand-held battery-powered tool for the following applications:

- For slitting sectional sheets such as trapezoidal sheet, corrugated sheet, boxed sheet, offset profiled strips.
- Slitting plate-shaped workpieces made of a punchable material such as steel, aluminum, non-ferrous heavy metals and plastic.
- Nibbling straight or curved exterior and interior cutouts.
- For nibbling from scribed lines.

Note

The nibbling process produces cutting edges free of deformations.

2.2 Technical data

TruTool N 200	Other countries	USA
Voltage	18 V	18 V
Permissible material thickness:steel up to 400 N/mm ²	2.0 mm	0.08 in
Permissible material thickness:steel up to 600 N/mm ²	1.5 mm	0.06 in
Permissible material thickness:steel up to 800 N/mm ²	1.0 mm	0.039 in
Permissible material thickness:aluminum up to 250 N/mm ²	2.5 mm	0.1 in
Working Speed	1.6 m/min	5.2 ft/min
Idle stroke rate	1530/min	1530/min
Starting hole diameter	17 mm	0.67 in
Smallest radius for curved cutouts	4.0 mm	0.16 in
Cutting track width	8.0 mm	0.315 in
Weight without rechargeable battery	1.6 kg	3.5 lbs

Tab. 1

TruTool PN 200 TruTool PN 201	Other countries	USA
Voltage	18 V	18 V
Permissible material thickness:steel up to 400 N/mm ²	2.0 mm	0.079 in / 14 Ga

TruTool PN 200 TruTool PN 201	Other countries	USA
Permissible material thickness:steel up to 600 N/mm ²	1.5 mm	0.06 in / 16 Ga
Permissible material thickness:steel up to 800 N/mm ²	1.0 mm	0.039 in / 20 Ga
Permissible material thickness:aluminum up to 250 N/mm ²	3.0 mm	0.126 in / 11 Ga
Working Speed TruTool PN 200 TruTool PN 201	1.9 m/min	6.3 ft/min
Idle stroke rate	1530/min	1530/min
Starting hole diameter	24 mm	0.94 in
Radius	min. 50 mm	min. 2.0 in
Cutting track width	5.0 mm	0.2 in
Weight without rechargeable battery TruTool PN 200 TruTool PN 201	1.6 kg 1.8 kg	3.5 lbs 4.0 lbs

Tab. 2

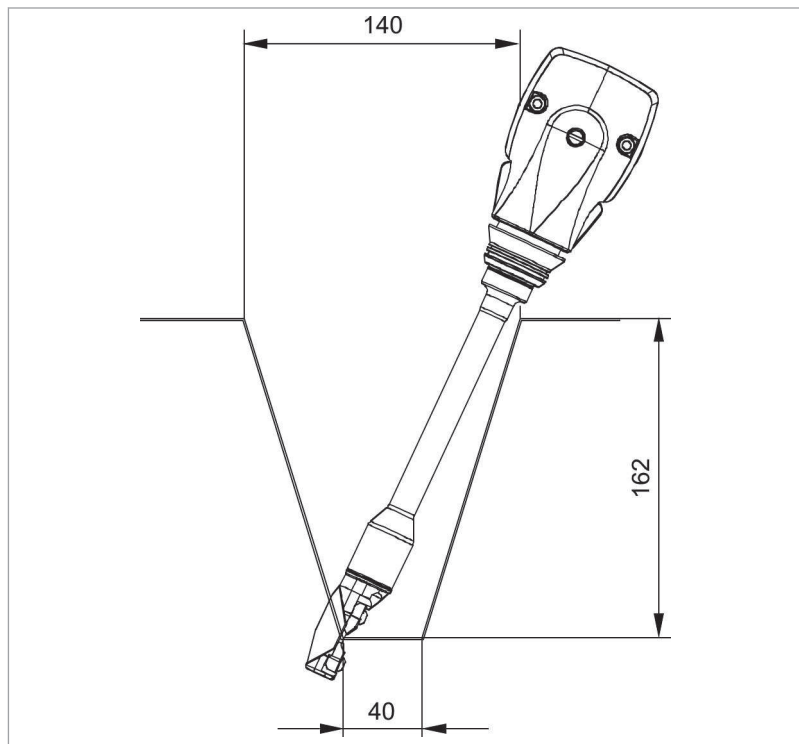

TruTool PN 201 in sectional sheets

Fig. 25947

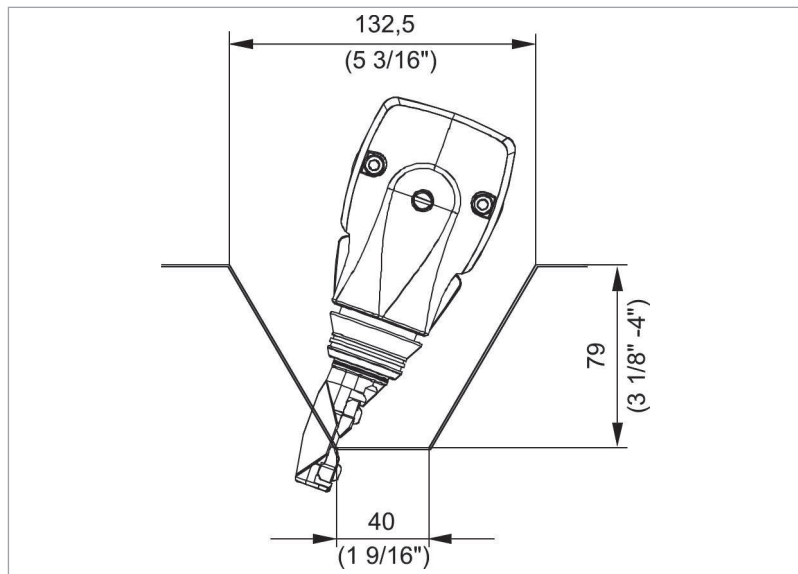

TruTool PN 200 in sectional sheets

Fig. 25948

2.3 Noise and vibration information

⚠ WARNING

Noise emission value may be exceeded.

- Wear hearing protection.

⚠ WARNING

The vibration emission value can be exceeded!

- Select the right tools and exchange them in time in the event of wear.
- Have maintenance carried out by trained specialized technicians.
- Define additional safety measures for protecting the operator from the effect of vibrations (e. g. keep hands warm, organization of working procedures, machining at normal feed force).
- Depending on the operating conditions and state of the electric tool, the actual load might be higher or lower than the specified measured value.

Notes

- The specified vibration emission value was measured in accordance with a standardized testing procedure and can be used to compare one electric tool with another.
- The specified vibration emission value can also be applied for a provisional estimate of the vibration load.

- Times during which either the machine is switched off or running but not actually in use can considerably reduce the vibration load during the entire working period.
- Times during which the machine works independently and self-propelled do not have to be calculated.



Designation of measured value	Unit	Value according to EN 60745
Vibration emission value a_h (vector sum of three directions)	m/s ²	N 200 (2A5): 8.0 PN 200 (2A5): 14.0 PN 201 (2A5): 19.1
Uncertainty K for vibration emission value	m/s ²	N 200 (2A5): 2.6 PN 200 (2A5): 2.3 PN 201 (2A5): 1.7
A-class acoustic pressure level L_{pA} typically	dB (A)	80
A-class acoustic power level L_{WA} typically	dB (A)	91
Uncertainty K for noise emission value	dB	3



Tab. 3

2.4 Icons

Note

The following symbols are important for reading and understanding the operator's manual. The correct interpretation of the symbols will help you operate the machine better and safer.

Icon	Name	Description
	Read operator's manual	Read the operator's manual and safety information in their entirety before starting up the machine. Closely follow the instructions given.
	Disposal	Batteries may not be disposed of in domestic waste! They contain harmful substances which are damaging to health and the environment. All dealers of TRUMPF machines in the EU and the USA accept empty batteries without charge.
Ni Cd		The characters under the symbols stand for: Battery contains nickel Battery contains cadmium

Icon	Name	Description
	Information symbol	Do not throw batteries into fire.
	Information symbol	Do not charge a damaged battery, but replace it immediately.
	Direct current	Type or property of current
V	Volt	Voltage
Ah	Ampere hours	Electrical load
Wh	Watt hours	Electrical work
mm	Millimeters	Dimensions e.g.: material thickness, chamfer length
in	Inch	Dimensions e.g.: material thickness, chamfer length
n_0	Idle speed	Revolution speed without load

Tab. 4

3. Setting work

3.1 Select tool (TruTool N 200 / TruTool PN 200 / TruTool PN 201)



Tooling

Fig. 111294

Any tool can be fastened to the basic machine.

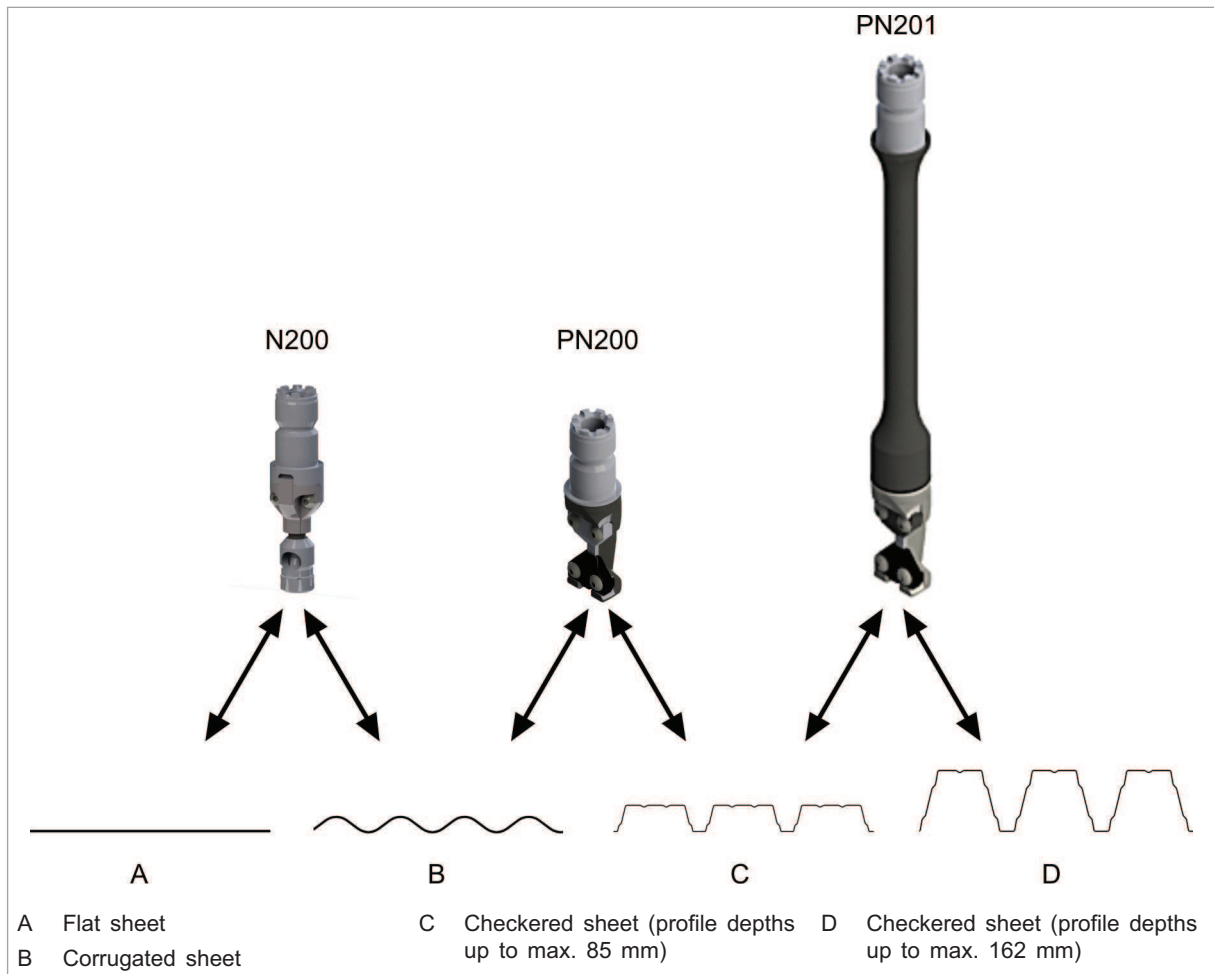

Areas of application

Fig. 66445

Burr-free cut To make a burr-free cut up to 1 mm thick in the sheet with the tools TruTool PN 200 and TruTool PN 201, the die P1 can be used. The lower cutting clearance reduces burr formation.

3.2 Setting the speed

- Use the setting wheel to set the revolution speed depending on the application.

3.3 Chip bag (optional)

A chip bag can be used to catch the chips.



Chip bag

Fig. 111295

4. Operation

WARNING

Risk of injury due to improper handling!

- Make sure the machine is always in a stable position when operating it.
- Never touch the tool while the machine is running.
- Always operate the machine away from your body.
- Do not operate the machine above your head.

Lubricating oil In order to improve the cutting result and increase the service life of the punch, coat the cutting track with oil before machining the workpiece.

4.1 Working with the TruTool N 200 / TruTool PN 200 / TruTool PN 201

Switching on 1. Push the On/Off switch forwards until it engages.

Processing the material

2. Once the full speed has been reached: move the machine toward the workpiece.
3. Process the desired cutting line.
4. If the cutting track ends in the sheet: retract the running machine a few millimeters in the direction of the already free-cut cutting track.

Switching off **Note**

Do not place a decelerating machine in the chips. The chips can be sucked in by the motor.

5. Press the rear part of the On/Off switch.
The motor switches off.

4.2 Changing the cutting direction

The direction of the cut can be rotated to the right or the left in 45° increments as needed.

- For right-handed/left-handed operation.
- To machine sectional sheets

1. Loosen the index bolt (about 3 revolutions) until no more resistance can be felt.

2. Pull the tool down slightly and turn it in the desired direction. There is a detent position every 45° (cutting direction).
3. Push the tool back up and tighten the index bolt.
4. Check: if no air gap can be seen between the housing and the tool, the tool is mounted correctly.

Carrier is engaged.

4.3 Nibbling with templates (TruTool N 200)

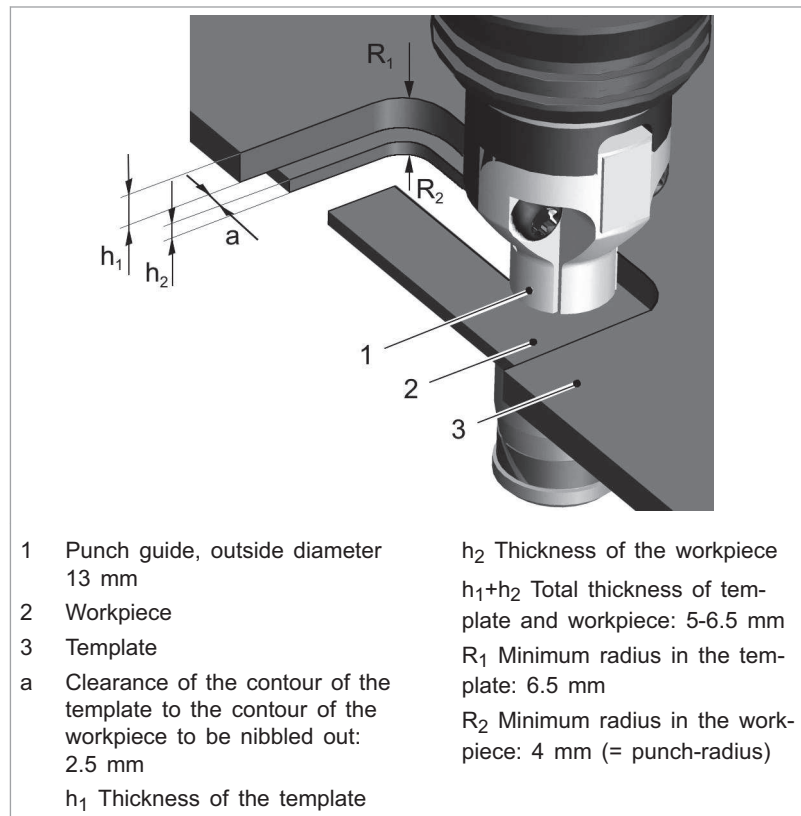

Fig. 25828

The following requirements must be met when nibbling with templates:

- The template must be at least 5 mm thick.
- There must be a clearance of 2.5 mm between the contour of the template and the contour to be nibbled out.
- The nibbler must be guided in such a way that the exterior cutout of the punch guide (1) always remains up against the template.
- Observe a minimum radius of 4 mm.

4.4 Producing interior cutouts

- TruTool N 200:
Produce start bore with at least a 17 mm diameter.
- TruTool PN 200 / TruTool PN 201:
Produce start bore with at least a 24 mm diameter.

5. Maintenance



Risk of injury from rechargeable battery!

- Remove the rechargeable battery before changing the tool or undertaking any maintenance work on the machine.



Risk of injury due to incorrect repair work

Machine does not work properly.

- Maintenance may be carried out by trained specialist technicians only.



Damage to property caused by blunt tools!

Machine overload.

- Check the cutting edge of the punch hourly for wear. A sharp punch provides good cutting performance and is easier on the machine. Change the punch in due time.

Maintenance point	Procedure and interval	Recommended lubricants
Punch guide	Lubricate upon tool change.	Lubricating grease "G5" (25 g)
Punch	Change as needed.	-
Die	Change as needed.	-
Wearing plate	Change as needed.	-
Ventilation slots	Clean as needed.	-
Gearbox and gear head	Every 300 operating hours, have a trained specialist relubricate or replace the lubricating grease.	Lubricating grease "G5" (900 g)

Maintenance positions and intervals for TruTool N 200 / TruTool PN 200 / TruTool PN 201

Tab. 5

5.1 Replacing the tool

If the punch and/or die are blunt, they must be replaced.

Disassembling the punch

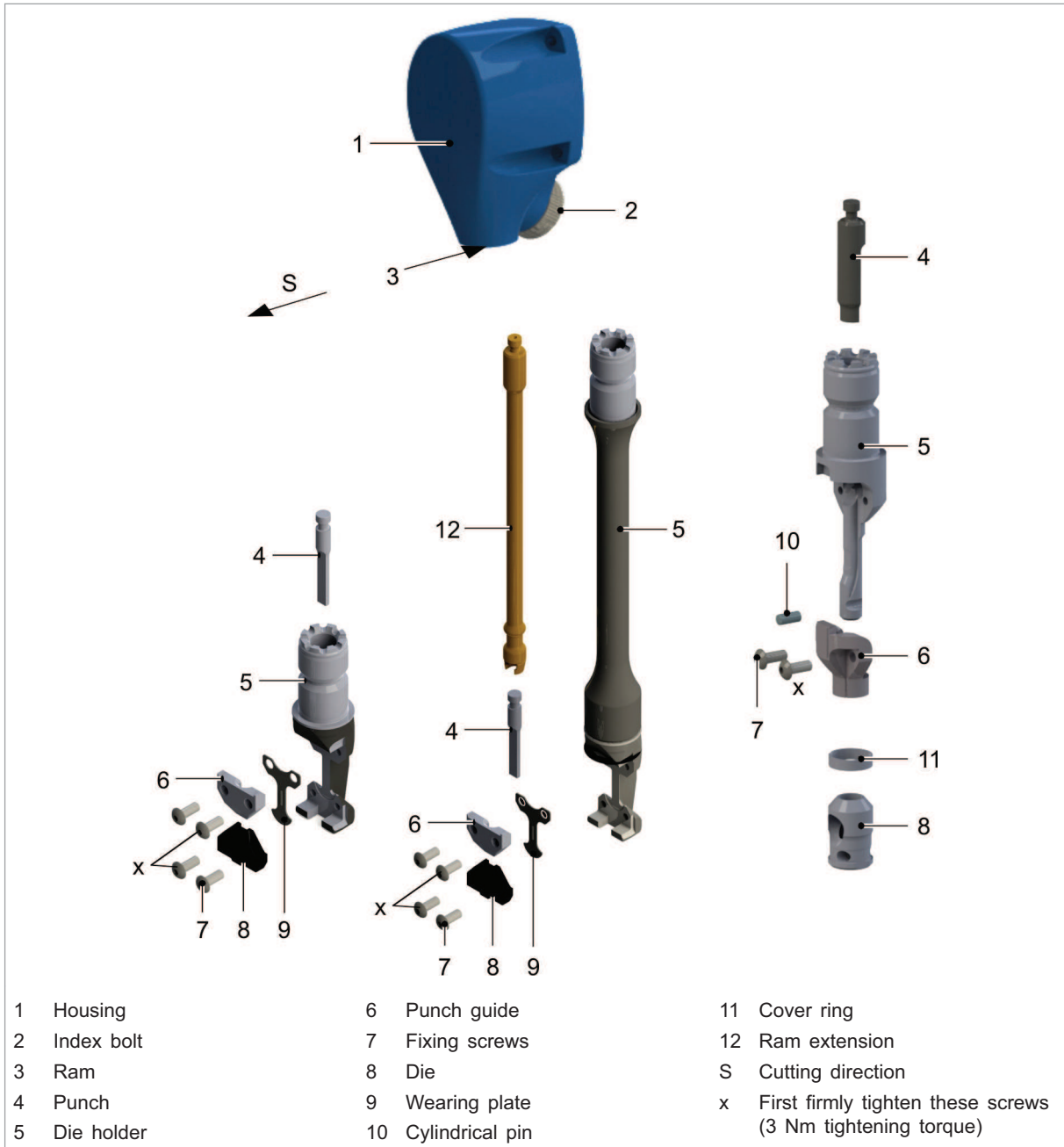

Fig. 65143

1. Loosen index bolt (2) (6 revolutions).
2. Pull tool out of the housing (1).
3. Remove punch (4).

Installing the punch

4. Lightly lubricate the new punch (4) and the boring in the tool with lubricating grease "G5".
5. For TruTool PN 201:

- Install the ram extension (12) between the ram (3) and the punch (4).
 - Grease with lubricating grease "G5".
6. Hang the punch in the keyway of the ram.
 7. Align the cutting direction towards the front.
 8. Insert tool into the housing (1) with cutting direction facing towards the front.
 9. Position the tool in the desired cutting direction.
 10. Tighten the index bolt (2) all the way.
 11. Gap between housing (1) and die holder (5) must be 0 mm.

**Replacing the die
(TruTool N 200)**

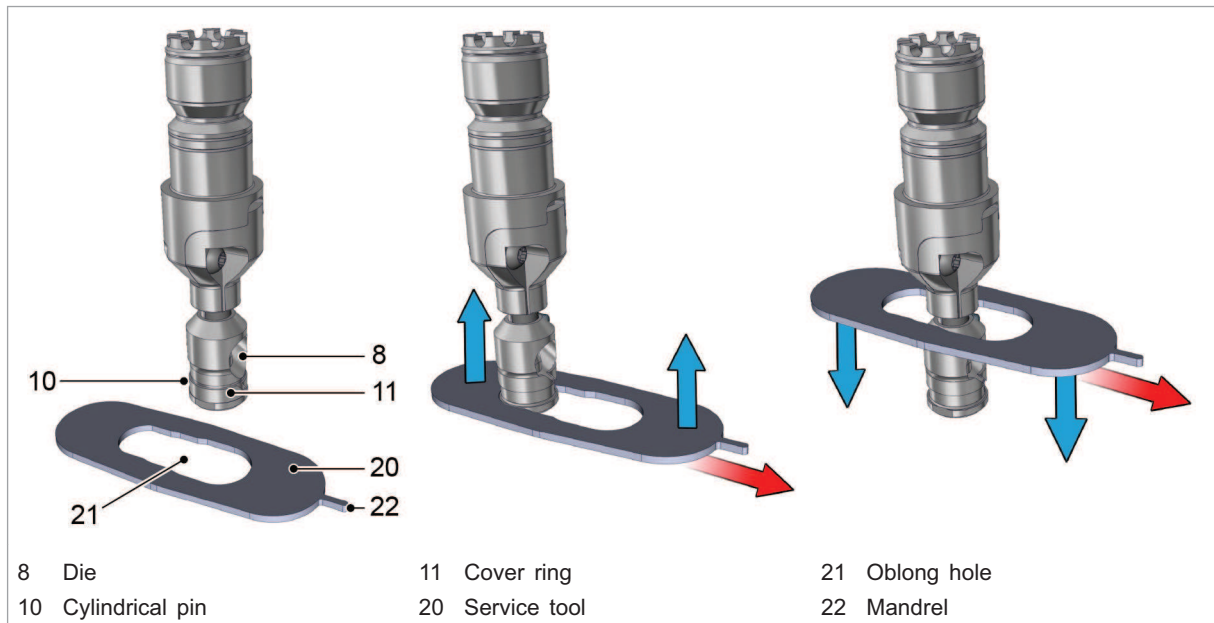

Service tool

Fig. 111176

12. Push cover ring (11) out of slot towards the casing top. Use the service tool for changing the die (20) for this. The tool is formed with a three-stage oblong hole (21). The widest point of the oblong hole (23) allows for alignment over the die. Subsequently moving the tool to the narrower side (24) allows the cover ring to be moved. The service tool must be moved towards the narrow side (25) until the edges of the inner oblong hole are flush with the end of the cover ring. Now the special tool can be moved towards the casing top (26) such that the cover ring moves with it.
13. Push out cylindrical pin (10) using the pin on the service tool (22)(see "Fig. 65143", pg. 17).
14. Pull off die (8) from the carrier pin and replace it with a new die.
15. Set die on the carrier pin.
16. Mount cylindrical pin.

17. Slide the cover ring into the slot. To do this, slide the service tool over the die (8), then attach to the cover ring as above by moving (27) the tool and remove in the opposite direction (28).

5.2 Changing the die, punch guide and wearing plate (TruTool PN 200 / TruTool PN 201)

1. Unscrew the fixing screws (7).
2. Remove punch guide (6) and die (8).

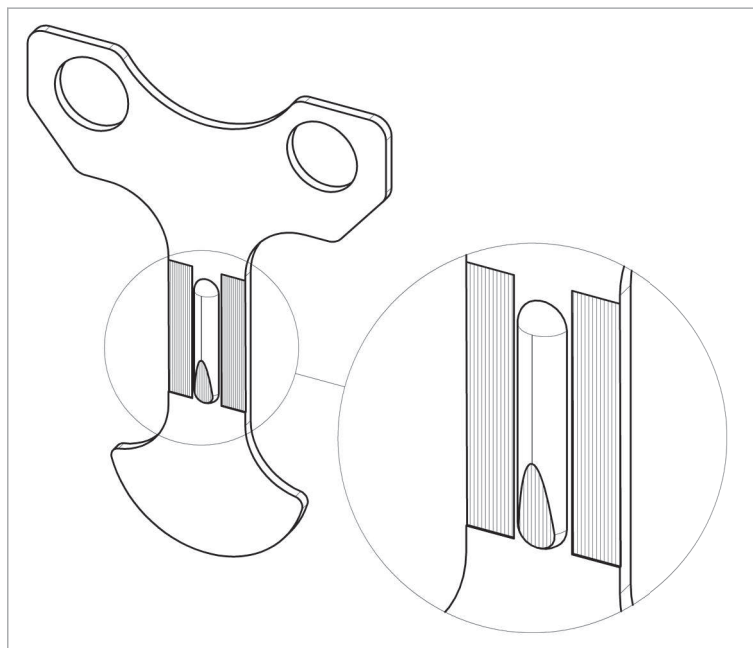

Traces of wear on the wearing plate

Fig. 51965

3. As soon as traces of wear (see image) can be clearly seen on the wearing plate, remove the wearing plate (9) and replace it with a new one.
4. Clean the support areas on the die carrier.
5. Center the punch guide and die using the pegs.
6. Fasten the punch guide and die with the screws.

Note

To grease, use lubricating grease "G5".

7. Lubricate the guide surfaces of the punch guide.

Note

Use original screws only.

8. Firmly tighten the screws marked with an "x" first (3 Nm tightening torque).

5.3 Checking loading status

The rechargeable battery pack has a capacity and signal display.

- Press the red button on the rechargeable battery pack. The charging status is shown by the LED lights.

If an LED light is flashing, the rechargeable battery pack is nearly empty and must be recharged.

5.4 Changing rechargeable battery

Condition

- Machine is switched off.

Taking out exchangeable battery



Changing rechargeable battery

Fig. 73106

1. Press rechargeable battery pack releasing device and remove battery pack.

Inserting exchangeable battery

2. Insert the rechargeable battery pack until it locks into place.

6. Accessories and consumables

Consumables TruTool PN 200 / TruTool PN 201	Order number	Scope of delivery
Punch		
1 piece	-	x
5-pack	1315713	-
10-pack	1264146	-
Complete die		
1 piece	-	x
2-pack	1264153	-
5-pack	1264154	-
Die P1		
1 piece	2260209	-
Wearing plate		
1 piece	-	x
2-pack	1429275	-
5-pack	1429276	-
Punch guide		
1 piece	1884927	x
2-pack	1264367	-
Standard PN set		
2 x punches, 1 x die, 2 x wearing plates	1429289	-
TruTool PN 200 tool	2287065	x ²
TruTool PN 201 tool	2287067	x ²

Tab. 6

Consumables, TruTool N 200	Order number	Scope of delivery
Punch		
1 piece	-	x
5-pack	1264176	-
Complete die		
1 piece	-	x
2-pack	1264393	-
5-pack	1264394	-
Standard N set		
2 x punches, 1 x die	0961961	-
Punch guide	1884925	x
TruTool N 200 tool	2286021	x ¹

Tab. 7

1 Depending on the machine type ordered.

Accessories	Order number	Scope of delivery
TRUMPF Box S2 (TruTool N 200 and PN 200)	1763682	x
TRUMPF Box S 204 lining (TruTool N 200 and PN 200)	2578313	x
TRUMPF Box M2 (only TruTool PN 200 Set and PN 201)	1770890	x
TRUMPF Box M 207 lining (only TruTool PN 200 Set and PN 201)	2578315	x
Screwdriver Torx T-20	1775531	x
Operator's manual	2581931	x
Safety information	0125699	x
Punching and nibbling oil for aluminum (1 l)	0125874	-
Punching and nibbling oil for steel (0.5 l)	0103387	-
		-
Chip bag (only TruTool N 200)	0088622	-

TruTool N 200, TruTool PN 200, TruTool PN 201

Tab. 8

Consumables rechargeable battery	Order number	Scope of delivery
Rechargeable battery pack 18 V / 4 Ah LiHD	2598811	x ²
Recharger 220 - 240 V, 50/60 Hz (D)	2569784	x ²
Recharger 115 V, 60 Hz (USA)	2569785	x ²
Recharger 220 - 240 V, 50/60 Hz (GB)	2569786	x ²

Tab. 9

6.1 Ordering consumables

Note

The following data must be specified in order to ensure that parts are delivered correctly and without delay.

1. Specify the order number.
2. Enter further order data:
 - Voltage data
 - Quantity
 - Machine type
3. Specify the complete shipping information:
 - Correct address.
 - Desired delivery type (e.g. air mail, courier, express mail, ordinary freight, parcel post).

Note

For TRUMPF service addresses, see www.trumpf-powertools.com.

2 Depending on the type of machine ordered

-
4. Send the order to the TRUMPF representative office.

**7. Appendix: Declaration of conformity,
guarantee, replacement parts lists**